

Calipers



THE ESSENTIALS

Calipers are the most popular length measuring instruments used worldwide. Owing to their simple construction, ease of handling and quick operation, they are a favourite for dimensional measurement. The wide variety of models available with specialised measuring faces make them universal hand-held tools.

All TESA, ETALON, INTERAPID branded calipers are recognised for their superior quality – and guarantee you precise measurement. The flawless guide of the slider on the beam ensures silky-smooth operation whilst also preventing the measuring jaws from tilting.

The choice of material, subjected to precisely defined heat treatment as well as a robust design result in further distinctive advantages such as wear and corrosion resistance.

For quick and easy reading of measured values – one of the essential conditions for the assurance of your measurements – we offer conventional vernier models as well as dial models for easy reading and digital models for error-free reading.

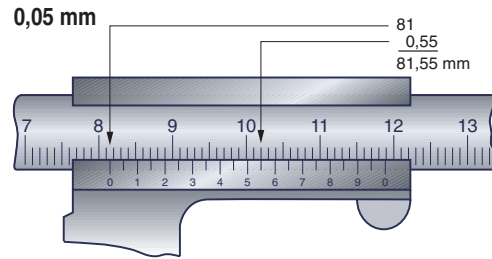
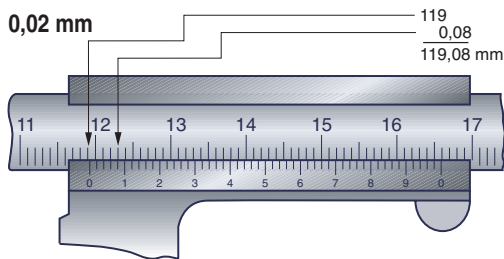

Chosen Length L mm	0,1 mm 0,05 mm μm	0,02 mm μm	0,01 mm μm
50	50	20	20
100	50	20	20
150	50	30	30
300	50	30	30
400	60	30	30
500	70	30	30
600	80	30	30
700	90	40	40
800	100	40	40
900	110	40	40
1000	120	40	40
1200	140	50	
1400	160	50	
1600	180	60	
1800	200	60	
2000	220	60	

The max. permissible errors (G) are expressed by the equation given below, where the values should be rounded down to two decimal fractions (0,01 mm). These errors apply for measurements taken under the same measuring force. For all other measurements, including those performed with use of the depth foot, the values obtained have to be increased by 20 μm.

Calipers with dial or vernier reading to 0,1 or 0,05 mm :
 $G = (20 + l / 10 \text{ mm}) \mu\text{m} \geq 50 \mu\text{m}$

Calipers with analogue indication (scale or vernier reading to 0,02 mm) or digital indication :
 $G = (22 + l / 50 \text{ mm}) \mu\text{m}$

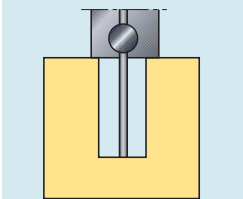
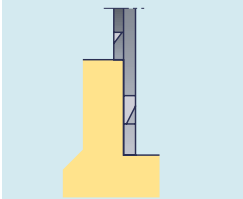
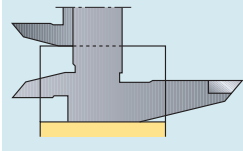
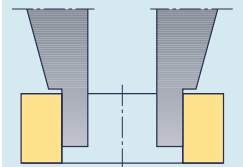
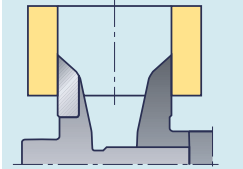
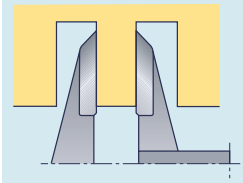
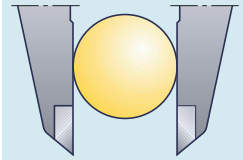

- ISO 13385-1
- 0,01 mm / 0.0005 in
- LCD, 11 mm
- Fixed zero
- mm / in conversion
- ≤ 100 mm: 20 µm
>100 mm: 30 µm
- 10 µm
- Scale with incremental divisions, inductive
- 2,5 m/s
- TLC Connectivity
- Stainless steel
- Lithium battery, 3V, CR2032
- 12.000 hours
- Standby mode after 10 minutes, instrument retains the zero position. Automatic shut off after 2 hours, instrument retains the zero in ABS mode, but the zero must be reset if the instrument is in DIFF mode.
- 1907/2006/CE
2004/108/CE
2002/96/CE
- Inspection report and declaration of conformity

TWIN-CAL IP67

Welcome to the new generation of TESA electronic calipers, with the highest degree of protection ever offered.

The TWIN-CAL IP67 are all equipped with TLC (TESA Link Connector), the unique integral data output facility, providing the opportunity to upgrade your caliper at any time.

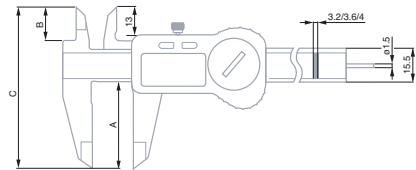

No	mm	in	Drive system / Thumb Roller	A mm	B mm	C mm	g	Depth rod
00530319	150	6	–	40	16	74	150	Square
00530320	150	6	–	40	16	74	150	Round
00530321	150	6	With	40	16	74	150	Round
00530322	200	8	With	50	20	90	200	Square
00530323	300	12	With	64	22	106	280	Square

OPTIONAL ACCESSORIES:

00560013	Depth foot for calipers up to 150 mm
01961000	Lithium battery, 3V, CR2032
04760180	TESA TLC-TWIN wireless emitter-receiver Compatible with any instrument fitted with a TLC – TESA Link Connector
04760181	TESA TLC-USB cable for instruments with a TLC connector
04760182	TLC-DIGIMATIC cable for instruments with a TLC connector



TWIN-CAL IP40

The new TWIN-CAL calipers are all supplied with a built in data output port. Simply plug the TESA TLC connector into the TWIN-CAL and the other end into a PC and all your measurement results will be captured and stored for optimal SPC monitoring.



- ISO 13385-1
- 0,01 mm / 0.0005 in
- LCD, 11 mm
- Fixed zero
- mm/in conversion
- ≤ 100 mm: 20 µm
>100 mm: 30 µm
- 10 µm
- Scale with incremental divisions, inductive
- 2,5 m/s
- TLC connectivity
- Stainless steel
- 3V Lithium battery, CR2032
- 12.000 hours
- Standby mode after 10 minutes, instrument retains zero. Automatic shut off after 2 hours. The instrument retains zero in ABS mode, but if the instrument is in DIFF mode, the zero must be reset.
- 1907/2006/CE
2004/108/CE
2002/96/CE
- Inspection report with declaration of conformity

	mm	in	Drive system / Thumb roller	A mm	B mm	C mm	g	Depth rod
00530094	150	6	With	40	16	74	150	Round
00530097	150	6	-	40	16	74	150	Square
00530095	200	8	With	50	20	90	200	Square
00530096	300	12	With	64	22	106	280	Square

OPTIONAL ACCESSORIES:

00560013	Depth foot for calipers up to 150 mm
01961000	Lithium battery, 3V, CR2032
04760180	TESA TLC-TWIN wireless emitter-receiver Compatible with any instrument fitted with a TLC – TESA Link Connector
04760181	TESA TLC-USB cable for instruments with a TLC connector
04760182	TLC-DIGIMATIC cable for instruments with a TLC connector

TESA VALUeline IP67

TESA Valueline is designed to meet customer demand for affordable products that don't compromise on the expertise associated with TESA. With TESA technology at their core, these products are of guaranteed quality.

- ISO 13385-1
- 0,01 mm / 0.0005 in
- LCD, 11 mm
- Fixed zero
- mm / in conversion
- ≤ 100 mm = 20 µm
>100 mm = 30 µm
- 10 µm
- Scale with incremental divisions, capacitive
- 2,5 m/s
- Stainless steel
- 3V Lithium battery, CR2032
- 1.5 to 2 years
- Standby mode after 10 minutes, instrument retains zero. Automatic shut off after 2 hours. The instrument retains zero in ABS mode, but if the instrument is in DIFF mode, the zero must be reset.
- 1907/2006/CE
2004/108/CE
2002/96/CE
- Inspection report with declaration of conformity

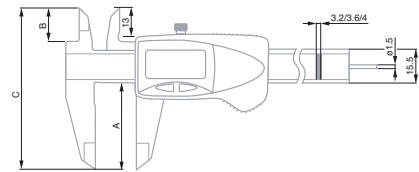
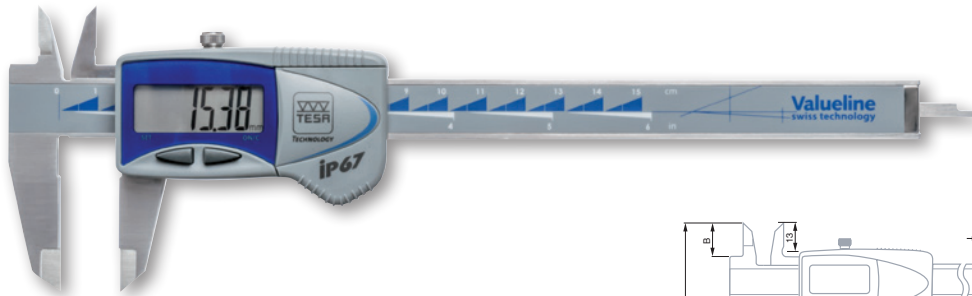

	mm	in	Drive system/ thumb roller	A mm	B mm	C mm	g	Depth rod
00539390	150	6	–	40	16	74	150	Square
00539391	150	6	–	40	16	74	150	Round
00539392	200	8	With	50	20	90	200	Square
00539393	300	12	With	64	22	106	280	Square
OPTIONAL ACCESSORIES:								
01961000	Lithium battery, 3V, CR2032							
00560013	Depth foot for calipers up to 150 mm							



DIAL CALIPERS

The dial caliper is the favourite instrument of many professionals working in mechanics, as it is an ideal tool for the workshop.

All dial calipers use the original shockproof technology developed and patented in 1970 by TESA, pioneer of this technology. Thanks to the shockproof system inserted between the mobile measuring element and the mechanism of the dial pointer, this patent guarantees reliable measurements even in case of a shock to the instrument.

Models TESA CCMA-M

Easy-to-read dial calipers – Slider with metal dial housing – Models with a 200 or 300 measuring span are fitted with a thumb roller.

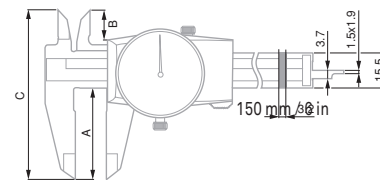
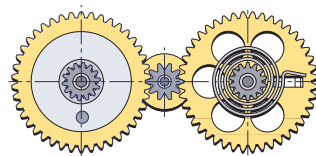
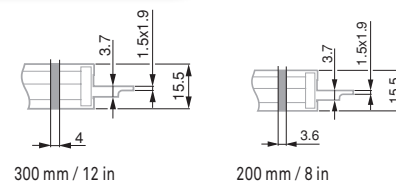
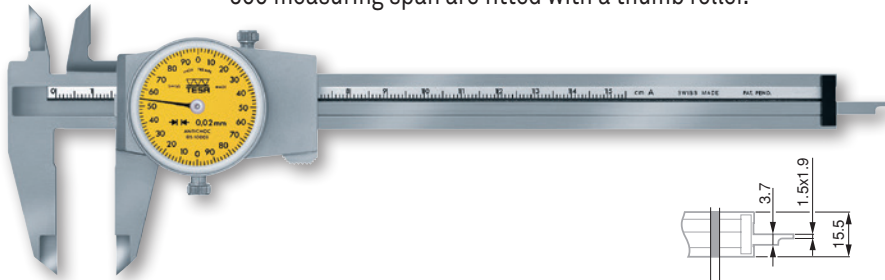

No	mm	mm	mm	A	Thumb roller	A mm	B mm	C mm
00510008	0 ÷ 150 mm	0,02 mm	2 mm	-	-	40	13	74
00520002	0 ÷ 6 in	0.001 in	0.1 in	-	-	40	13	74
00510045	0 ÷ 200 mm	0,02 mm	2 mm	●	●	50	18,6	89,5
00510046	0 ÷ 300 mm	0,02 mm	2 mm	●	●	64	20,6	105,5

OPTIONAL ACCESSORY:
00560013 Depth foot for calipers up to 150 mm

Model TESA CCMA-M, 0,01 mm

Slider with metal dial housing – 1 mm per dial revolution.

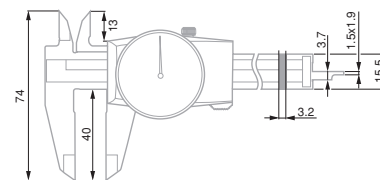
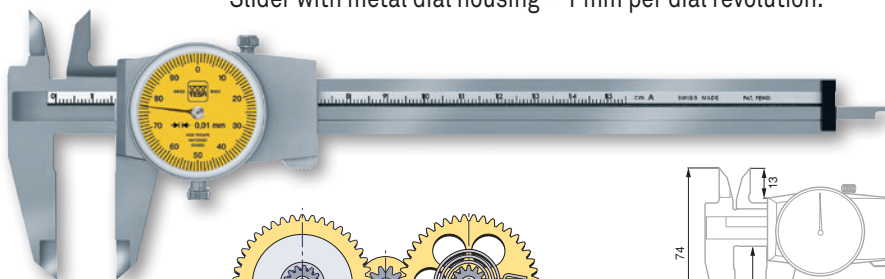

No	mm	mm	mm
00510050	0 ÷ 150 mm	0,01	1 mm

OPTIONAL ACCESSORY:
00560013 Depth foot for calipers up to 150 mm

- DIN 862 (Style 1AR)
- ≤ 100 mm = 20 µm
>100 mm = 30 µm
- Gear mechanism made of hardened ground steel
- Hardened stainless steel
- Inspection report with a declaration of conformity
- 32 mm diameter rotating dial with lock
- Slider with locking screw
- Patented shockproof design

- DIN 862 (Style 1AR)
- ≤ 100 mm = 20 µm
>100 mm = 30 µm
- Gear mechanism made of hardened ground steel
- Hardened stainless steel
- Inspection report with a declaration of conformity
- 32 mm diameter rotating dial with lock
- Slider with locking screw
- Patented shockproof design

- DIN 862 (Style 1AR)
- $\leq 100 \text{ mm} = 20 \mu\text{m}$
 $>100 \text{ mm} = 30 \mu\text{m}$
- Gear mechanism made of hardened, ground steel
- Hardened stainless steel
- Inspection report with a declaration of conformity
- 32 mm diameter rotating dial with lock
- Slider with plastic dial housing and locking screw
- Patented shockproof design

TESA CCMA-P Models

Quick and easy to read – Slider with plastic dial housing.

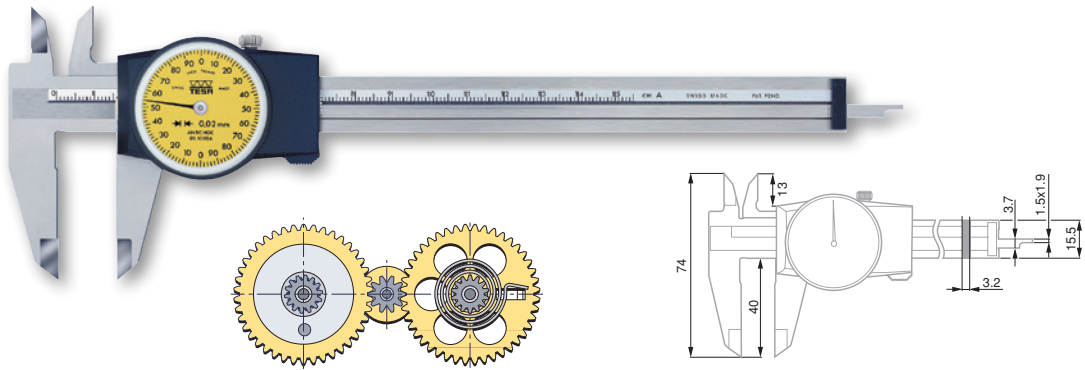

00510004	0 ÷ 150 mm	0,02 mm	2 mm	Without thumb wheel
00520001	0 ÷ 6 in	0.001 in	0.1 in	Without thumb wheel
OPTIONAL ACCESSORY:				
00560013	Depth foot for calipers up to 150 mm			

- DIN 862 (Style 1AR)
- $\leq 100 \text{ mm} = 20 \mu\text{m}$
 $>100 \text{ mm} = 30 \mu\text{m}$
- Gear mechanism made of hardened, ground steel
- Hardened stainless steel
- Inspection report with a declaration of conformity
- 32 mm diameter rotating dial with lock
- Slider with locking screw
- Patented shockproof design

ETALON 125 Model

Slider with metal dial housing – 1 mm travel per dial revolution.

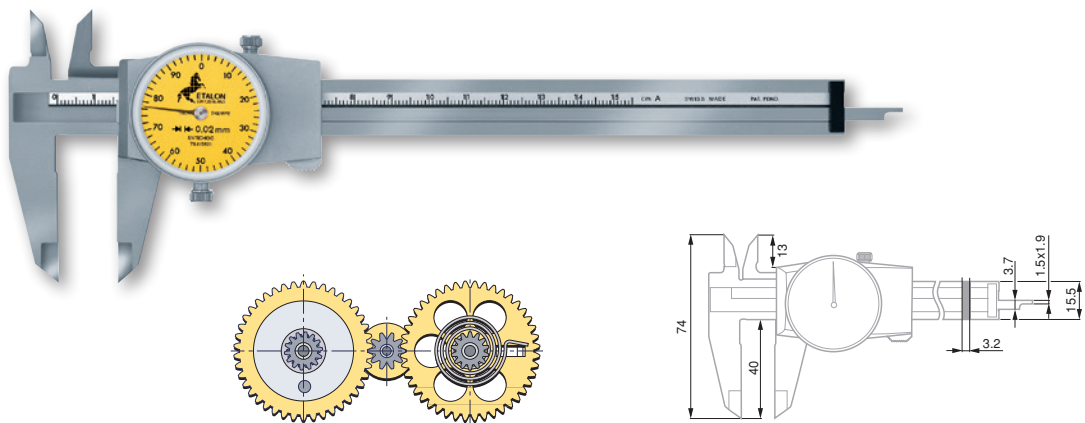

075115821	0 ÷ 150 mm	0,02 mm	1 mm	Without thumb wheel
OPTIONAL ACCESSORY:				
00560013	Depth foot for calipers up to 150 mm			



ACCESSORIES FOR CALIPERS



Accessories for standard calipers

-  Hardened stainless steel
-  Ground measuring face

Depth Measuring Foot

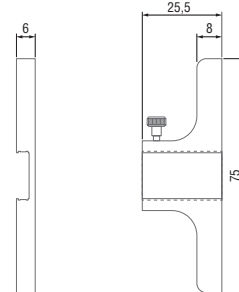
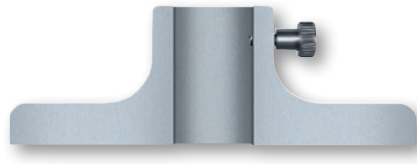
For use with TESA or ETALON universal calipers with a measuring span of 0 to 150 mm / 0 to 6 inch.





		
00560013	Depth foot for calipers up to 150 mm	mm 75 x 6

Magnetic Magnifying Glass

Can be mounted on calipers and other such instruments for easier reading of vernier scales.

-  2 permanent magnets



		
0051610365	Magnetic magnifying glass, 3x magnification	

N DIN 862
(Style 1AN-2)
NFE 11-091

O Maximum
permissible errors,
in accordance with
standard

S Hardened stainless
steel

I Inspection report
with a declaration
of conformity

A Satin-chrome scale
background; main
scale slightly set
back for protection
against wear

VERNIER CALIPERS

The simplest calipers to use with engraved scales for reading very fine divisions on measurements.

Standard Models

Calipers offering great value for money:

- Fitted with a locking screw.
- With rectangular or round depth rod.

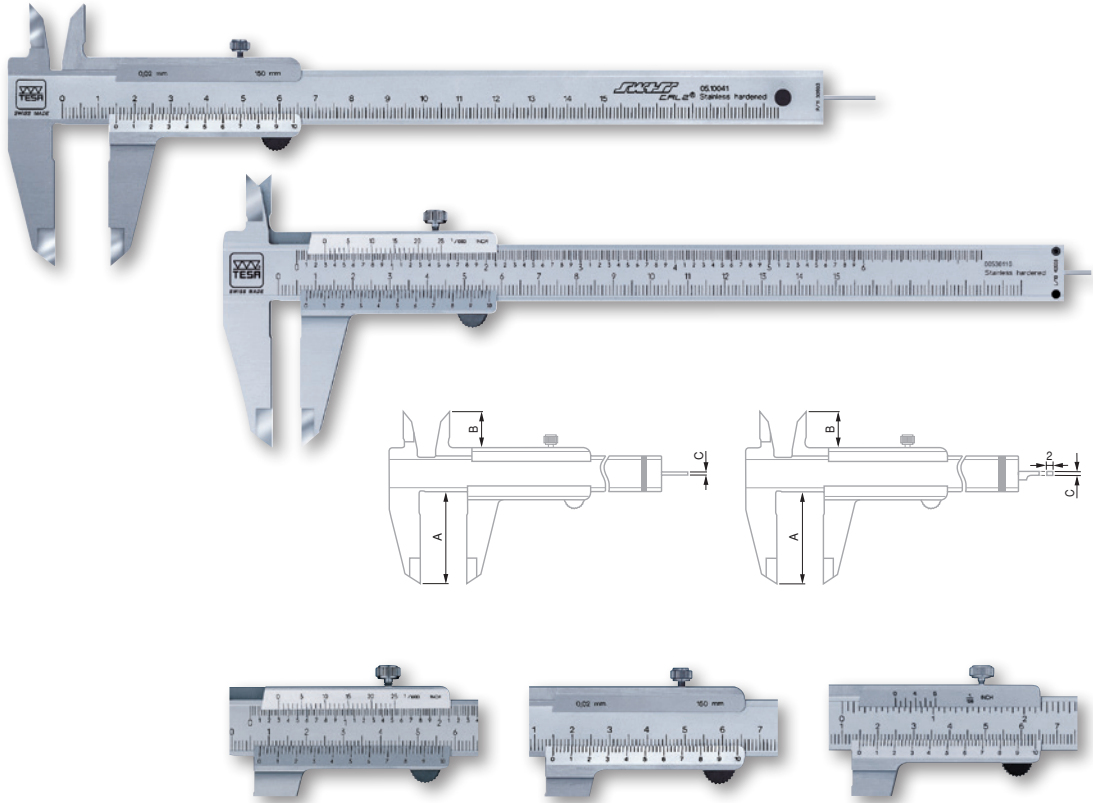

No	=					A mm	B mm	C mm
00510041	SWISSCAL 2	0 ÷ 150	–	0,02	–	40	15,5	Ø 1,5
00510047	Standard	0 ÷ 150	–	0,05	–	40	15,5	Ø 1,5
00530103	Standard	0 ÷ 150	0 ÷ 6	0,05	1/128	40	15,5	Ø 1,5
00530104	Standard	0 ÷ 200	0 ÷ 8	0,05	1/128	50	18	1,5 x 2
00530105	Standard	0 ÷ 300	0 ÷ 12	0,05	1/128	64	22	–
00530110	Standard	0 ÷ 150	0 ÷ 6	0,02	0.001	40	15,5	Ø 1,5
00530111	Standard	0 ÷ 200	0 ÷ 8	0,02	0.001	50	18	1,5 x 2
00530112	Standard	0 ÷ 300	0 ÷ 12	0,02	0.001	64	22	–
00530120	Self-locking model	0 ÷ 150	0 ÷ 6	0,05	1/128	40	15,5	1,5 x 2
00530121	Self-locking model	0 ÷ 150	0 ÷ 6	0,02	0.001	40	15,5	1,5 x 2
00530130	Self-locking model with parallax-free readout	0 ÷ 150	0 ÷ 6	0,05	1/128	40	15,5	1,5 x 2
00530131	Self-locking model with parallax-free readout	0 ÷ 150	0 ÷ 6	0,02	0.001	40	15,5	1,5 x 2

OPTIONAL ACCESSORIES:

00560013 Depth foot for calipers up to 150 mm

0051610365 Magnetic magnifying glass, 3x magnification



WORKSHOP DIGITAL CALIPERS

Large-dimension calipers are equipped with a very precise measuring system and flawless guide of the slider on the beam. This know-how makes them the most accurate calipers available on the market.

The range of IP67 calipers guarantees the highest level of protection against the penetration of dust and liquids. The TLC (TESA Link Connector) system built into all the TwinCal calipers provides the connection of these instruments to a PC for the easy acquisition of measurement data. The unique display housing, protected by a steel plate surrounded with a rubber seal guarantees durability and offers fine sensitivity during measurement.

TWIN-CAL IP67 – Models with Rounded Measuring Faces for Internal Dimensions

- Complete IP67 protection against the penetration of dust and liquids, even when the cable is connected.
- Unique TWIN connectivity concept allowing for upgrade across the range.

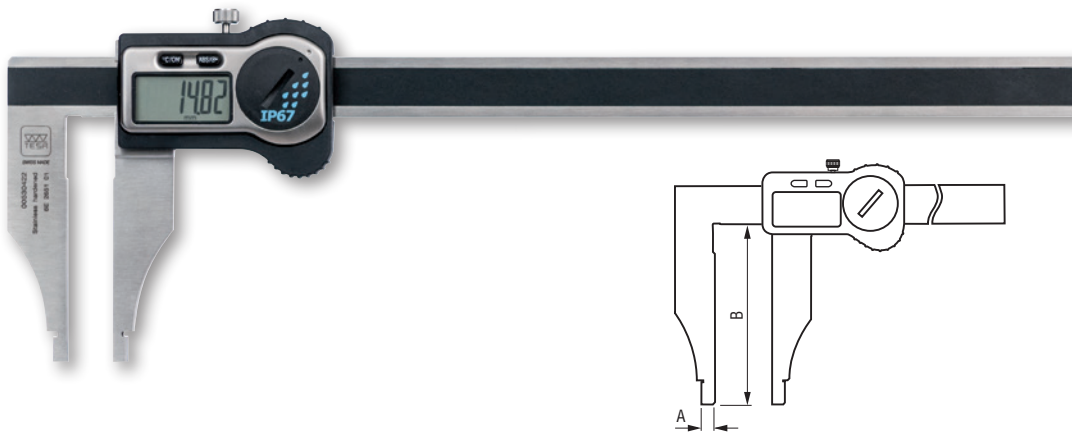

No	mm	in	A mm	B mm
00530421	200	8	5	80
00530422	250	10	5	80
00530423	300	12	5	90
00530424	500	20	10	150
00530425	600	24	10	150
00530426	800	32	10	150
00530427	1000	39	10	150

OPTIONAL ACCESSORIES:

01961000	Lithium battery, 3V, CR2032
04760180	TESA TLC-TWIN wireless emitter-receiver Compatible with any instrument fitted with a TLC – TESA Link Connector
04760181	TESA TLC-USB cable for instruments with a TLC connector
04760182	TLC-DIGIMATIC cable for instruments with a TLC connector

- ISO 13385-1
- 0,01 mm / 0,0005 in
- LCD, 11 mm
- Fixed zero
- mm / in conversion
- L ≤ 100 mm: 30 µm
100 < L ≤ 600 mm: 40 µm
600 < L ≤ 1000 mm: 50 µm
- 10 µm
- Scale with incremental divisions, inductive
- 2,5 m/s
- TLC Connectivity
- Stainless steel
- 3V Lithium battery, CR2032
- 12.000 hours
- Standby mode after 10 minutes, instrument retains the zero position. Automatic shut off after 2 hours, instrument retains the zero in ABS mode, but the zero must be reset if the instrument is in DIFF mode.
- 1907/2006/CE
2004/108/CE
2002/96/CE
- Inspection report with declaration of conformity

- ISO 13385-1
- 0,01 mm / 0.0005 in
- LCD, 11 mm
- Fixed zero
- mm / in conversion
- L ≤ 100 mm: 30 μm
100 < L ≤ 600 mm: 40 μm
600 < L ≤ 1000 mm: 50 μm
- 10 μm
- Scale with incremental divisions, inductive
- 2,5 m/s
- TLC Connectivity
- Stainless steel
- 3V Lithium battery, CR2032
- 12.000 hours
- Standby mode after 10 minutes, instrument retains the zero position. Automatic shut off after 2 hours, instrument retains the zero in ABS mode, but the zero must be reset if the instrument is in DIFF mode.
- 1907/2006/CE
2004/108/CE
2002/96/CE
- Inspection report with declaration of conformity

TWIN-CAL IP67 – Models with Rounded Measuring Faces for Internal Dimensions and Knife-edge Jaws for External Dimensions

- Complete IP67 protection against the penetration of dust and liquids, even when the cable is connected
- Unique TWIN connectivity concept allowing for upgrade across the range.

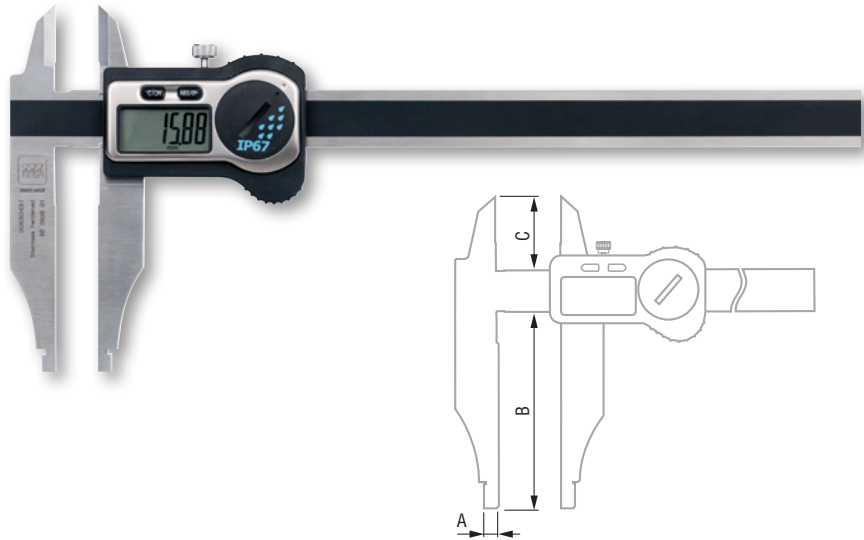

No					
00530431	200	8	5	80	30
00530432	250	10	5	80	37
00530433	300	12	5	90	37
00530434	500	20	10	150	60
00530435	600	24	10	150	60
00530436	800	32	10	150	56
00530437	1000	39	10	150	56

OPTIONAL ACCESSORIES:

01961000	Lithium battery, 3V, CR2032
04760180	TESA TLC-TWIN wireless emitter-receiver Compatible with any instrument fitted with a TLC – TESA Link Connector
04760181	TESA TLC-USB cable for instruments with a TLC connector
04760182	TLC-DIGIMATIC cable for instruments with a TLC connector



TWIN-CAL IP67 – Models with Rounded Measuring Faces for Internal Dimensions and Knife-edge Jaws for Internal Dimensions

- Complete IP67 protection against the penetration of dust and liquids, even when the cable is connected
- Unique TWIN connectivity concept allowing for upgrade across the range.



- ISO 13385-1
- 0,01 mm / 0.0005 in
- LCD, 11 mm
- Fixed zero
- mm / in conversion
- L ≤ 100 mm: 30 µm
100 < L ≤ 250 mm: 40 µm
- 10 µm
- Scale with incremental divisions, inductive
- 2,5 m/s
- TLC Connectivity
- Stainless steel
- 3V Lithium battery, CR2032
- 12.000 hours
- Standby mode after 10 minutes, instrument retains the zero position. Automatic shut off after 2 hours, instrument retains the zero in ABS mode, but the zero must be reset if the instrument is in DIFF mode.
- 1907/2006/CE
2004/108/CE
2002/96/CE
- Inspection report with declaration of conformity

No	mm	in	A mm	B mm	C mm
00530430	250	10	5	80	54
OPTIONAL ACCESSORIES:					
01961000	Lithium battery, 3V, CR2032				
04760180	TESA TLC-TWIN wireless emitter-receiver Compatible with any instrument fitted with a TLC – TESA Link Connector				
04760181	TESA TLC-USB cable for instruments with a TLC connector				
04760182	TLC-DIGIMATIC cable for instruments with a TLC connector				

- DIN 862 (Style EN-2) NFE 11-091
- Maximum permissible errors in accordance with standard
- Hardened stainless steel
- Inspection report with a declaration of conformity
- Satin-chrome scale background; main scale set back slightly for protection against wear.

VERNIER CALIPERS

The simplest calipers to use with engraved scales for reading very fine divisions on measurements.

Models with Rounded Measuring Faces for Internal Dimensions (Without Fine Adjust Device)

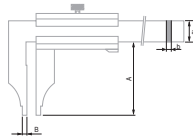
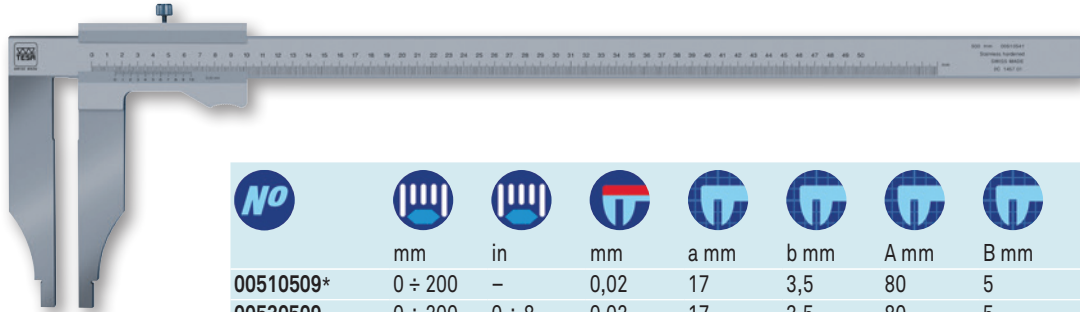

No							
	mm	in	mm	a mm	b mm	A mm	B mm
00510509*	0 ÷ 200	–	0,02	17	3,5	80	5
00530509	0 ÷ 200	0 ÷ 8	0,02	17	3,5	80	5
00510506	0 ÷ 200	–	0,05	17	3,5	80	5
00510511	0 ÷ 250	–	0,02	20	4	90	5
00510512	0 ÷ 250	–	0,05	20	4	90	5
00510521	0 ÷ 300	–	0,02	20	4	90	5
00530521	0 ÷ 300	0 ÷ 12	0,02	20	4	90	5
00510522	0 ÷ 300	–	0,05	20	4	90	5
00510531	0 ÷ 400	–	0,02	24,5	5	125	10
00530531	0 ÷ 400	0 ÷ 15	0,02	24,5	5	125	10
00510541	0 ÷ 500	–	0,02	28	6	150	10
00510542	0 ÷ 500	–	0,05	28	6	150	10
00510551	0 ÷ 600	–	0,02	28	6	150	10

OPTIONAL ACCESSORY:

0051610365 Magnetic magnifying glass, 3x magnification

* Supplied with a flexible stainless steel rule, 200 mm long, part code 0951750181

- DIN 862 (Style EN-2F) NFE 11-091
- Maximum permissible errors in accordance with standard
- Hardened stainless steel
- Inspection report with a declaration of conformity
- Satin-chrome scale background; main scale set back slightly for protection against wear

Models with Rounded Measuring Faces for Internal Dimensions (With Fine Adjust Device)

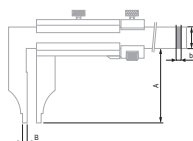
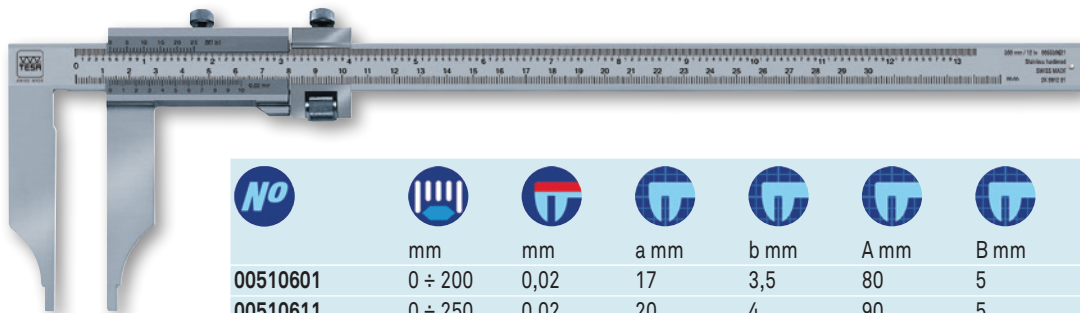

No						
	mm	mm	a mm	b mm	A mm	B mm
00510601	0 ÷ 200	0,02	17	3,5	80	5
00510611	0 ÷ 250	0,02	20	4	90	5
00510621	0 ÷ 300	0,02	20	4	90	5
00510641	0 ÷ 500	0,02	28	6	150	10
00510651	0 ÷ 600	0,02	28	6	150	10
00510661	0 ÷ 800	0,02	32	8	150	10
00510671	0 ÷ 1000	0,02	32	8	150	10
00510681	0 ÷ 1500	0,02	40	8	300	15
00510691	0 ÷ 2000	0,02	40	8	300	15

OPTIONAL ACCESSORY:

0051610365 Magnetic magnifying glass, 3x magnification



Models with Knife-edge Jaws for External Dimensions and Rounded Measuring Faces for Internal Dimensions (Without Fine Adjust Device)

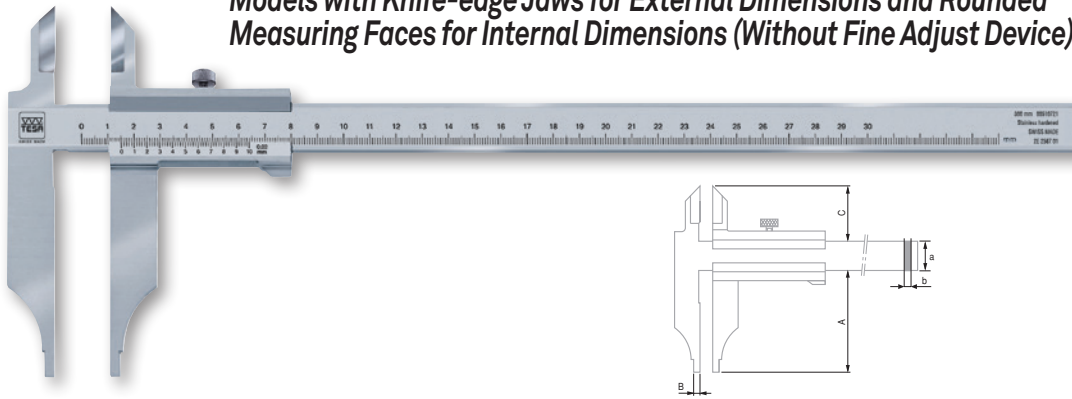

- DIN 862 (Style BN-2) NFE 11-091
- Maximum permissible errors, in accordance with standard
- Hardened stainless steel
- Inspection report with a declaration of conformity
- Satin-chrome scale background: main scale set back slightly for protection against wear

No								
00510701	0 ÷ 200	–	0,02	17	3,5	80	5	30
00530701	0 ÷ 200	0 ÷ 8	0,02	17	3,5	80	5	30
00510711	0 ÷ 250	–	0,02	20	4	80	5	38
00510721	0 ÷ 300	–	0,02	20	4	90	5	38
00530721	0 ÷ 300	0 ÷ 12	0,02	20	4	90	5	38
00510722	0 ÷ 300	–	0,05	20	4	90	5	38
00510741	0 ÷ 500	–	0,02	28	6	150	10	60
00530741	0 ÷ 500	0 ÷ 20	0,02	28	6	150	10	60
00510751	0 ÷ 600	–	0,02	28	6	150	10	60

OPTIONAL ACCESSORY:

0051610365 Magnetic magnifying glass, 3x magnification

Models with Knife-edge Jaws for External Dimensions and Rounded Measuring Faces for Internal Dimensions (With Fine Adjust Device)

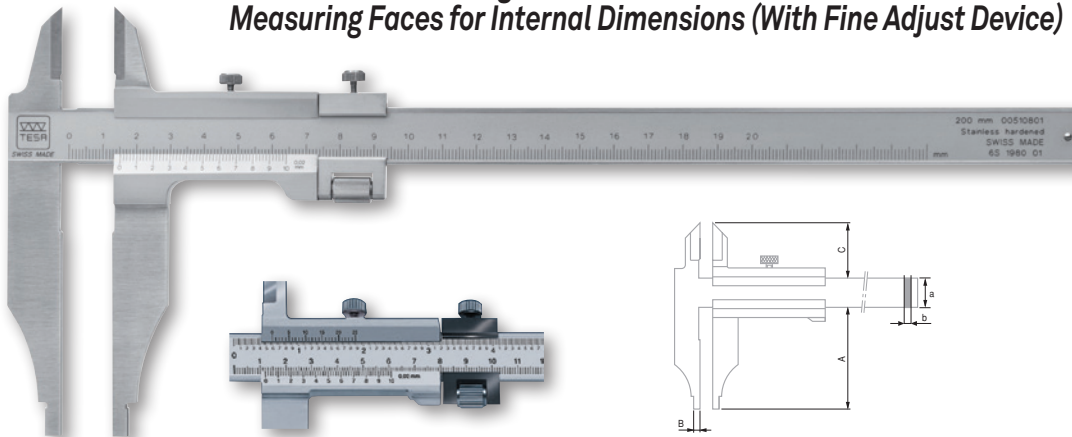

- DIN 862 (Style BN-2) NFE 11-091
- Maximum permissible errors, in accordance with standard
- Hardened stainless steel
- Inspection report with a declaration of conformity
- Satin-chrome scale background: main scale set back slightly for protection against wear

No								
00510801	0 ÷ 200	–	0,02	17	3,5	80	5	30
00510821	0 ÷ 300	–	0,02	20	4	90	5	38
00530821	0 ÷ 300	0 ÷ 11	0,02	20	4	90	5	38
00510841	0 ÷ 500	–	0,02	28	6	150	10	60
00530841	0 ÷ 500	0 ÷ 20	0,02	28	6	150	10	60
00510861	0 ÷ 800	–	0,02	32	8	150	10	56
00510871	0 ÷ 1000	–	0,02	32	8	150	10	56

OPTIONAL ACCESSORY:

0051610365 Magnetic magnifying glass, 3x magnification

- ISO 13385-1
- 0,01 mm / 0,0005 in
- LCD, 11 mm
- Fixed zero
- mm / in conversion
- L ≤ 100 mm: 30 µm
100 < L ≤ 600 mm: 40 µm
600 < L ≤ 1000 mm: 50 µm
- 10 µm
- Scale with incremental divisions, inductive
- 2,5 m/s
- TLC Connectivity
- Stainless steel
- 3V lithium battery, CR2032
- 12.000 hours
- Standby mode after 10 minutes, instrument retains the zero position. Automatic shut off after 2 hours, instrument retains the zero in ABS mode, but the zero must be reset if the instrument is in DIFF mode.
- 1907/2006/CE
2004/108/CE
2002/96/CE
- Inspection report with declaration of conformity

DIGITAL DEPTH CALIPERS

The range of IP67 calipers guarantees the highest level of protection against the penetration of dust and liquids. The TLC (TESA Link Connector) system built into all the TWIN-CAL calipers provides the connection of these instruments to a PC for the easy acquisition of measurement data. The unique display housing, protected by a steel plate surrounded with a rubber seal guarantees durability and offers fine sensitivity during measurement.

TWIN-CAL IP67 – Models with Short Cut Measuring Face

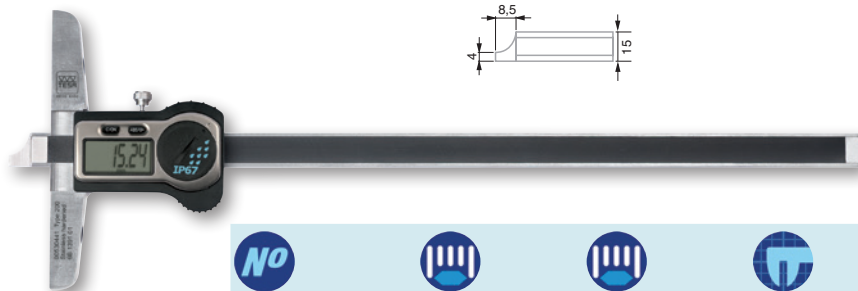
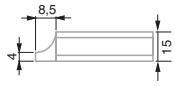
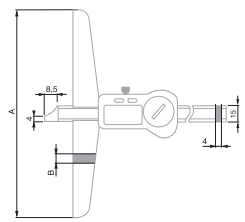
No	mm	in	A mm	B mm
00530441	200	8	100	8
00530442	250	10	100	8
00530443	300	12	150	8
00530444	500	20	150	8

TWIN-CAL IP67 – Models with One Fixed Measuring Jaw

No	mm	in	A mm	B mm
00530445	300	12	150	8
00530446	500	20	150	8

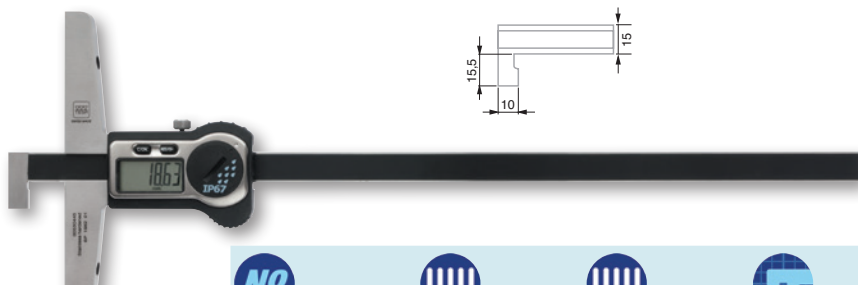
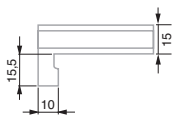
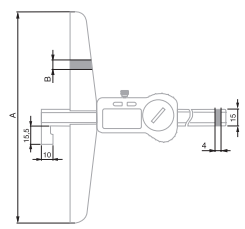
TWIN-CAL IP67 – Models with Two Fixed Measuring Jaws

No	mm	in	A mm	B mm
00530447	300	12	150	8

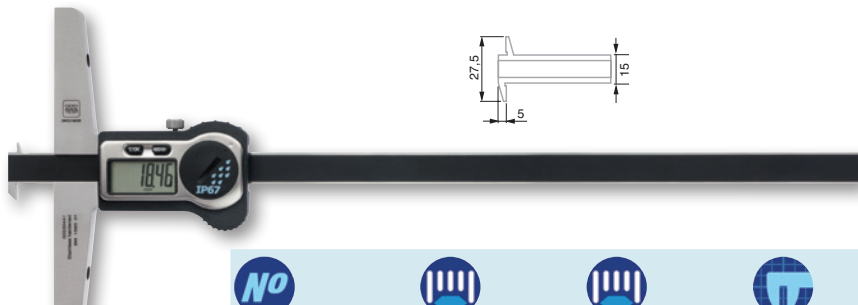
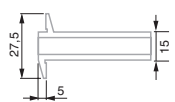
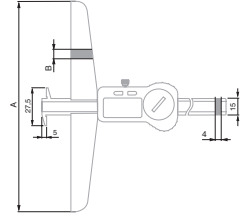

TWIN-CAL IP67 – Models with Rotary Stop Plate

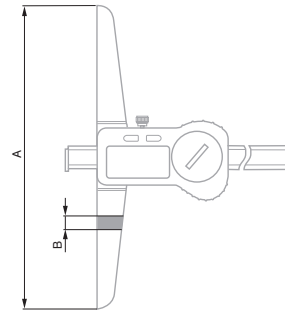
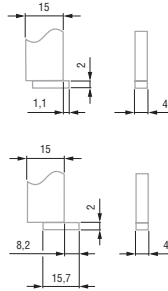
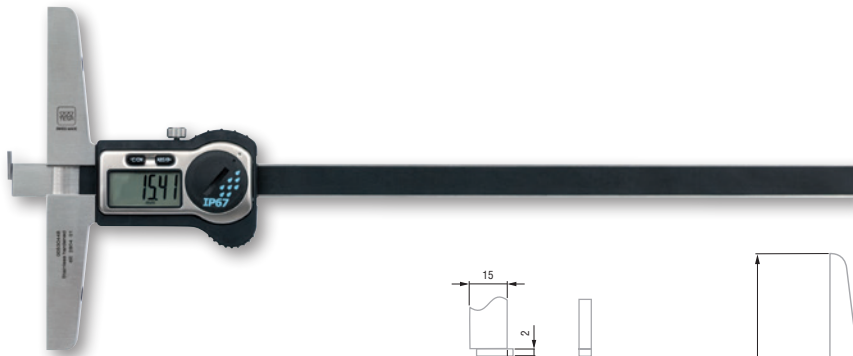

No	mm	in	A mm	B mm
00530448	250	10	150	8,5
00530449	350	14	150	8,5
00530450	500	20	150	8,5

OPTIONAL ACCESSORIES:

01961000	Lithium battery, 3V, CR2032			
04760180	TESA TLC-TWIN wireless emitter-receiver Compatible with any instrument fitted with a TLC – TESA Link Connector			
04760181	TESA TLC-USB cable for instruments with a TLC connector			
04760182	TLC-DIGIMATIC cable for instruments with a TLC connector			
00560103	Removable bridge 200 mm			
00560104	Removable bridge 300 mm			
00560105	Removable bridge 400 mm			

TWIN-CAL IP67 – Small Sized Model with Steel Measuring Tip

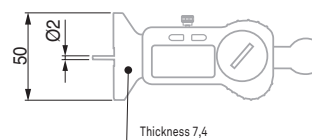

No	mm	in
00530451	25	1

OPTIONAL ACCESSORIES:

01961000	Lithium battery, 3V, CR2032	
04760180	TESA TLC-TWIN wireless emitter-receiver Compatible with any instrument fitted with a TLC – TESA Link Connector	
04760181	TESA TLC-USB cable for instruments with a TLC connector	
04760182	TLC-DIGIMATIC cable for instruments with a TLC connector	

- ISO 13385-1
- 0.01 mm / 0.0005 in
- LCD, 11 mm
- Fixed zero
- Metric / in conversion
- L ≤ 100 mm: 30 µm
100 < L ≤ 600 mm: 40 µm
600 < L ≤ 1000 mm: 50 µm
- 10 µm
- Scale with incremental divisions, inductive
- 2,5 m/s
- TLC Connectivity
- Stainless steel
- 3V lithium battery, CR2032
- 12.000 hours
- Standby mode after 10 minutes, instrument retains the zero position. Automatic shut off after 2 hours, instrument retains the zero in ABS mode, but the zero must be reset if the instrument is in DIFF mode.
- 1907/2006/CE
2004/108/CE
2002/96/CE
- Inspection report with declaration of conformity

- DIN 862 (Style C-2) NFE 11-096
- Maximum permissible errors: in accordance with standard
- Hardened stainless steel
- Inspection report with a declaration of conformity
- Satin-chrome scale background; main scale set back slightly for protection against wear

VERNIER DEPTH CALIPERS

Depth calipers with:

- Flat measuring face
- Convertible models, short cut measuring face or steel tip
- Rotary stop plate
- Convertible models, short cut measuring face or fixed hook



TESA Vernier Calipers with a Flat Measuring Face

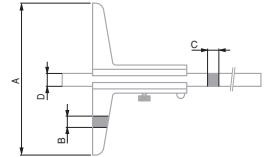

No						
	mm	mm	A mm	B mm	C mm	D mm
00510133	0 ÷ 150	0,02	100	7,5	3	8
00510134	0 ÷ 150	0,05	100	7,5	3	8
00510143	0 ÷ 250	0,02	100	7,5	3	8
00510163	0 ÷ 500	0,02	100	8,5	4	12
00510173	0 ÷ 600	0,02	150	8,5	4	12

- DIN 862 (Style C-2) NFE 11-096
- Maximum permissible errors: in accordance with standard
- Hardened stainless steel
- Inspection report with a declaration of conformity
- Satin-chrome scale background; main scale set back slightly for protection against wear

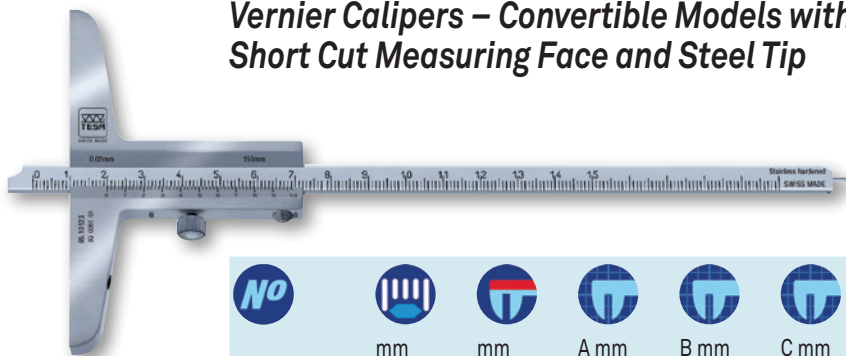

Vernier Calipers – Convertible Models with Short Cut Measuring Face and Steel Tip

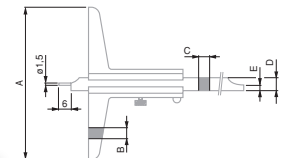

No							
	mm	mm	A mm	B mm	C mm	D mm	E mm
00510123	0 ÷ 150	0,02	100	7,5	3	8	3,5
00510124	0 ÷ 150	0,05	100	7,5	3	8	3,5
00510125	0 ÷ 250	0,02	100	7,5	3	8	4



Vernier Calipers with Rotary Stop Plate

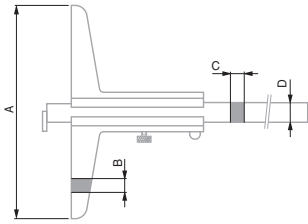
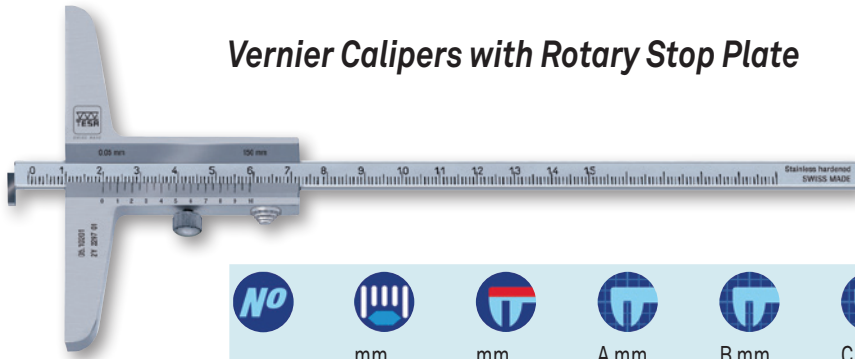

No						
	mm	mm	A mm	B mm	C mm	D mm
00510201	0 ÷ 150	0,05	130	8,5	4	12
00510202	0 ÷ 150	0,02	130	8,5	4	12
00510212	0 ÷ 250	0,02	130	8,5	4	12
00510222	0 ÷ 500	0,02	130	8,5	4	12

OPTIONAL ACCESSORIES:

0051610365	Magnetic magnifying glass, 3x magnification
00560103	Removable bridge 200 mm
00560104	Removable bridge 300 mm
00560105	Removable bridge 400 mm

Vernier Calipers – Convertible Models with Fixed Stop Plate and Short Cut Measuring Face

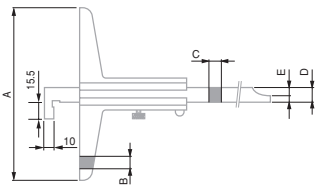

No							
	mm	mm	A mm	B mm	C mm	D mm	E mm
00510175	0 ÷ 150	0,02	100	7,5	3	8	3,5
00510177	0 ÷ 250	0,02	130	8,5	4	12	4
00510179	0 ÷ 300	0,02	150	8,5	4	12	4
00510181	0 ÷ 500	0,02	150	8,5	4	12	4

OPTIONAL ACCESSORIES:

0051610365	Magnetic magnifying glass, 3x magnification
00560103	Removable bridge 200 mm
00560104	Removable bridge 300 mm
00560105	Removable bridge 400 mm

Removable Bridges



Each bridge is delivered with the appropriate fixing screws

No						
	mm	µm	mm	A mm	B mm	C mm
00560103	± 0,005	8	0,02	200	11,5	10
00560104	± 0,005	10	0,02	300	16	16
00560105	± 0,005	10	0,03	400	16	16

- DIN 862 (Style C-2) NFE 11-096
- Maximum permissible errors: in accordance with standard
- Hardened stainless steel
- Inspection report with a declaration of conformity
- Satin-chrome scale background; main scale set back slightly for protection against wear

- DIN 862 (Style C-2) NFE 11-096
- Maximum permissible errors, in accordance with standard
- Hardened stainless steel
- Inspection report with a declaration of conformity
- Satin-chrome scale background; main scale set back slightly for protection against wear



ISO 13385-1

0,01 mm /
0,0005 in

LCD, 11 mm

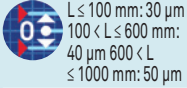

Fixed zero

mm / in
conversionL ≤ 100 mm: 30 μm
100 < L ≤ 600 mm:
40 μm
600 < L
≤ 1000 mm: 50 μm

10 μm

Scale with incre-
mental divisions,
inductive

2,5 m/s



TLC Connectivity



Stainless steel

3V Lithium battery,
CR2032

12.000 hours

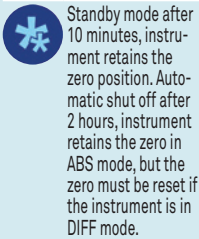
Standby mode after
10 minutes, instru-
ment retains the
zero position. Auto-
matic shut off after
2 hours, instrument
retains the zero in
ABS mode, but the
zero must be reset if
the instrument is in
DIFF mode.1907/2006/CE
2004/108/CE
2002/96/CEInspection report
with declaration
of conformity

SCALE UNITS

The IP67 scale units assure the highest degree of protection against the penetration of dust and liquids.





The integral TLC (TESA Link Connector) connectivity system common to the all the TWIN-CAL range allows the connection of all these instruments to a PC for easy data acquisition.

The unique display module, protected by a steel plate surrounded by rubber seal guarantees optimal durability and sensitivity during measurement.

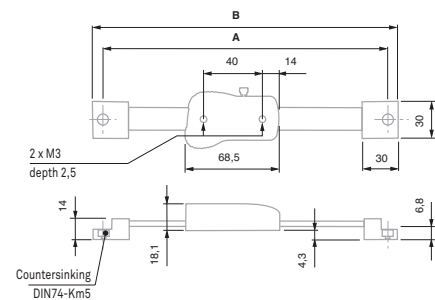
TWIN-CAL IP67 Horizontal Scale Unit

- Complete IP67 protection against the penetration of dust and liquids, even when the cable is connected
- Unique TWIN connectivity concept allowing for upgrade across the range



No				
00530471	150	6	265	278
00530473	300	12	415	428
00530474	600	24	725	738
00530475	1000	40	1135	1148

OPTIONAL ACCESSORIES:

01961000	Lithium battery, 3V, CR2032
04760180	TESA TLC-TWIN wireless emitter-receiver Compatible with any instrument fitted with a TLC – TESA Link Connector
04760181	TESA TLC-USB cable for instruments with a TLC connector
04760182	TLC-DIGIMATIC cable for instruments with a TLC connector



DIGITAL CALIPERS

For measurements up to 3000 mm.

INTERAPID Light

Measuring functions

- Zero setting
- Metric/Inch conversion
- Hold function for displayed value
- OPTO-RS data transfer, mono- and bi-directional
- Two adjustable points of origin (Ref I / Ref II)
- PRESET function
- MIN/MAX mode
- Two limit values for classification

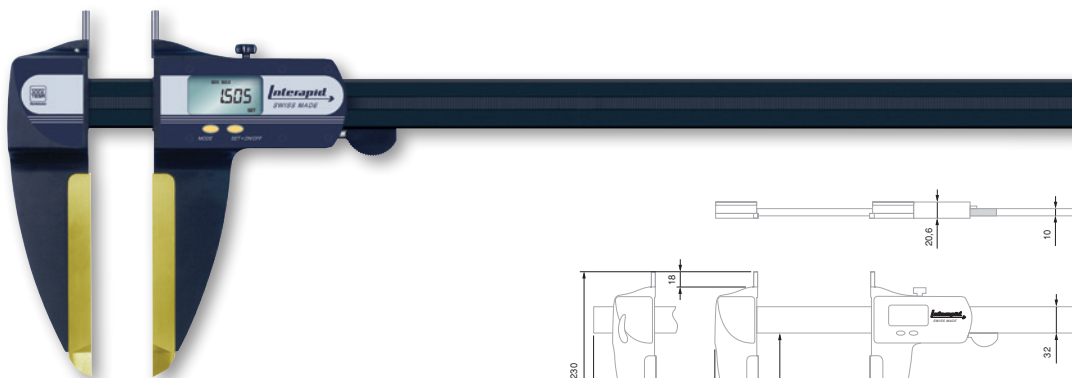

- DIN 862 and factory standard
- 0.01 mm / 0.0005 in
- LCD, 8,5 mm
- Fixed zero
- mm / in conversion
- Scale with incremental divisions, inductive
- > 1,5 m/s
- Hardened steel jaws for external dimensions. Also with TiN coating, thickness to 7 mm. Tungsten carbide inserts for internal dimensions, 5 mm dia. Beam with light alloy hollow section, supported by hardened stainless steel rods.
- 3V lithium battery, CR2032
- ≈ 1,5 a (≈ 3300 h / a)
- IP40 (IEC 60529)
- EN 50081-1
EN 50082-1
- Inspection report for models up to 1500 mm
- Display lock
- RS232 Opto-coupled, mono- and bi-directional

No							
	A mm	μm	μm	B Fixed	C Mobile	kg	
00590061	330	30	20	618	-	1,1	
00590062	630	40	20	918	-	1,3	
00590063	1025	60	20	-	1306	1,6	
00590064	1525	150	20	-	1806	2	
00590065	2040	250	30	-	2306	2,3	
00590066	2545	350	30	-	2806	2,6	
00590067	3050	450	40	-	3306	3	

OPTIONAL ACCESSORIES:

01961000	Lithium battery, 3V, CR2032
00560095	Insert-holder, M2,5 thread
00560096	60°conical steel pin in hardened steel
00560097	Holder for dial gauge inserts L = 28 mm
00560098	Holder for dial gauge inserts L = 58 mm
00560099	Wooden case for INTERAPID Light 300 mm
00560100	Wooden case for INTERAPID Light 600 mm
00560101	Wooden case for INTERAPID Light 1000 mm
00560102	Wooden case for INTERAPID Light 1500 mm

Accessories for INTERAPID Light

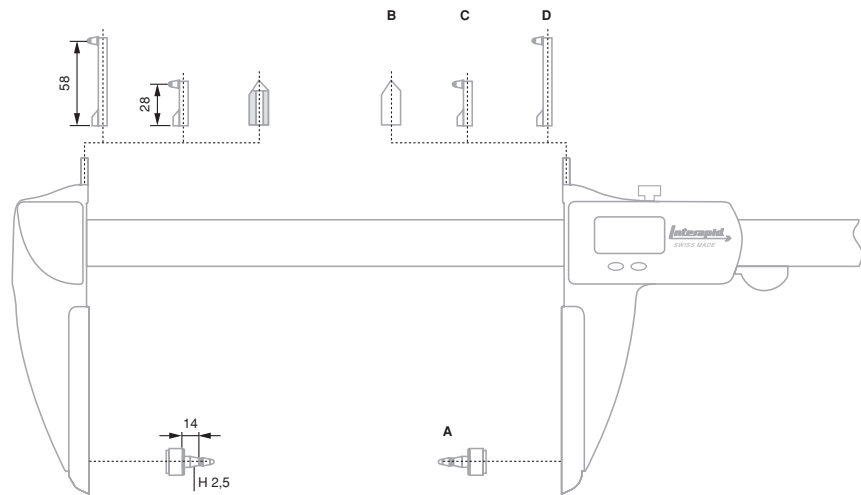

No	=	A
00560095	Insert-holder, M2,5 thread for measuring inserts	A
00560096	60° conical steel pin in hardened steel for measuring centre distances >10 mm	B
00560097	Holder for dial gauge inserts used for groove measurement, L = 28 mm	C
00560098	Holder for dial gauge inserts used for groove measurement, L = 58 mm	D
00560099	Wooden case for INTERAPID Light 300 mm	
00560100	Wooden case for INTERAPID Light 600 mm	
00560101	Wooden case for INTERAPID Light 1000 mm	
00560102	Wooden case for INTERAPID Light 1500 mm	



CALIPERS WITH SPECIAL DESIGN

Calipers designed for specific measuring tasks including:

- Models with extra long jaws
- Models with hook jaws for measuring grooves
- Models for measuring throat depth

- Factory standard
- Hardened stainless steel
- Inspection report with a declaration of conformity
- Satin-chrome scale background; main scale set back slightly for protection against wear

With Extra Long Jaws and Fine Adjust Device

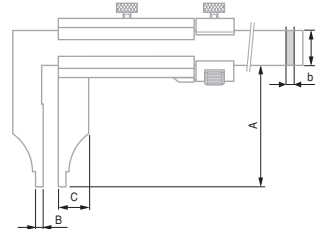
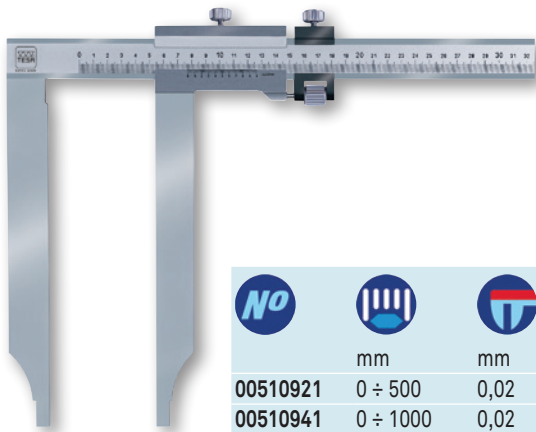

No							
	mm	mm	a mm	b mm	A mm	B mm	C mm
00510921	0 ÷ 500	0,02	28	6	250	10	30
00510941	0 ÷ 1000	0,02	32	8	300	10	30

OPTIONAL ACCESSORY:

0051610365 Magnetic magnifying glass, 3x magnification

With Hook Jaws for External Dimensions

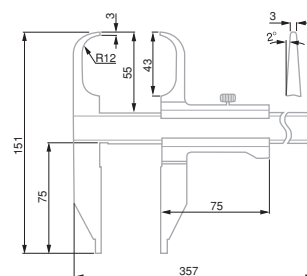
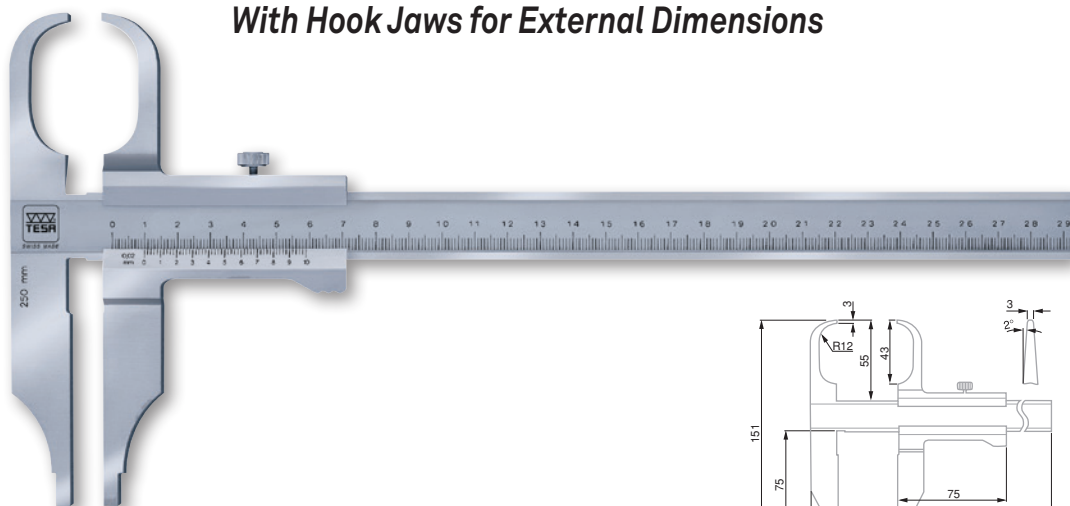

No		
	mm	mm
00510911	0 ÷ 250	0,02

OPTIONAL ACCESSORY:

0051610365 Magnetic magnifying glass, 3x magnification

- NFE 11-096
- Hardened stainless steel
- inspection report with declaration of conformity
- Satin-chrome scale background; main scale set back slightly for protection against wear

- DIN 862
(Style DN-2)
NFE 11-091
- Hardened stainless steel
- Inspection report with a declaration of conformity
- Satin-chrome scale background; main scale set back slightly for protection against wear

With Knife-edge Jaws for Internal Dimensions

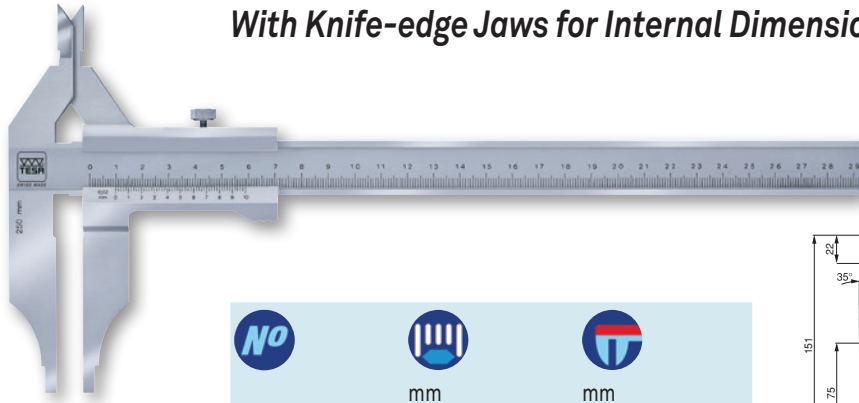

00510915	mm	0 ÷ 250
		0,02

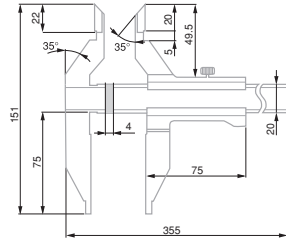

- NFE 11-096
- Hardened stainless steel
- Inspection report with a declaration of conformity
- Satin-chrome scale background; main scale set back slightly for protection against wear

With Vee Bridge

Made to measure groove and slot depths on cylindrical shafts.

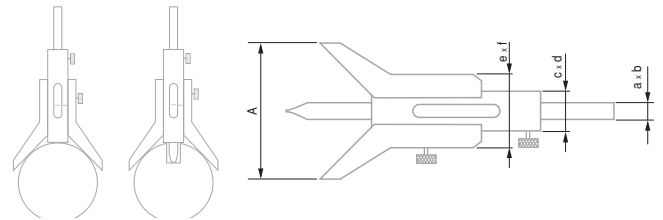
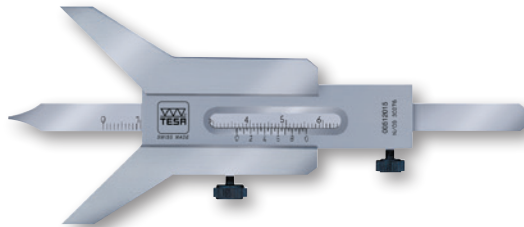

	mm	mm	a mm	b mm	c mm	d mm	e mm	f mm	A mm	
00512015	5 ÷ 80	0,05	8	2	18	5	32	10	60	
00512016	6 ÷ 120	0,05	8	2	18	5	34	10	90	
00512017	7 ÷ 160	0,05	10	2	21,5	5	42	10	120	

- Factory standard
- Hardened stainless steel
- Inspection report with a declaration of conformity
- Satin-chrome scale background; main scale set back slightly for protection against wear

For Turned Grooves

Specially designed for measuring groove or slot diameters, e.g. on safety rings.

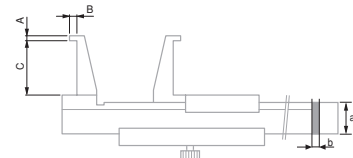
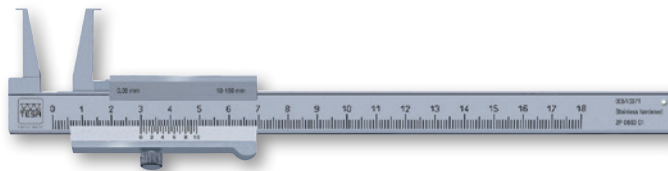

	mm	mm	a mm	b mm	A mm	B mm	C mm	
00510371	10 ÷ 160	0,05	16	3	0,9	3	25	
00510375	20 ÷ 160	0,05	16	3	2	5	40	
00510383	26 ÷ 200	0,02	16	3	3	7	60	
00510387	30 ÷ 250	0,02	20	4	4	8,5	80	
00510393	35 ÷ 300	0,02	20	4	5	10	100	



